

# **Basic Underride Information**

*A presentation in memory of  
North Carolina underride victims  
AnnaLeah & Mary Karth*

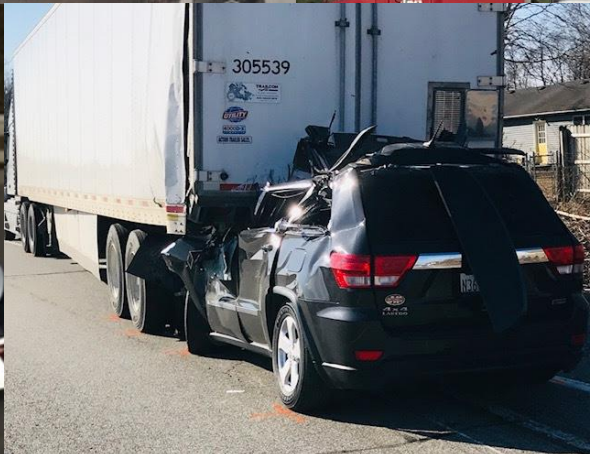

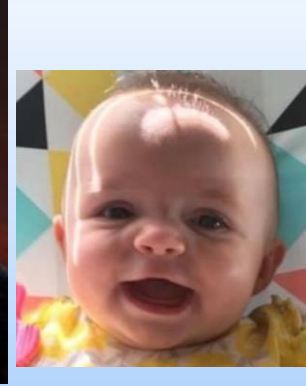

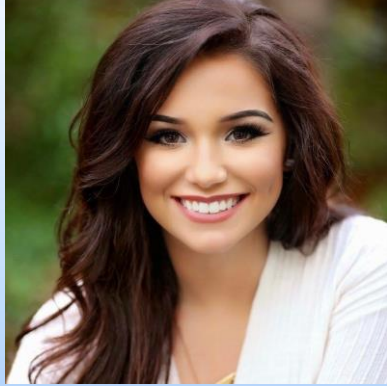

Their deaths were preventable.



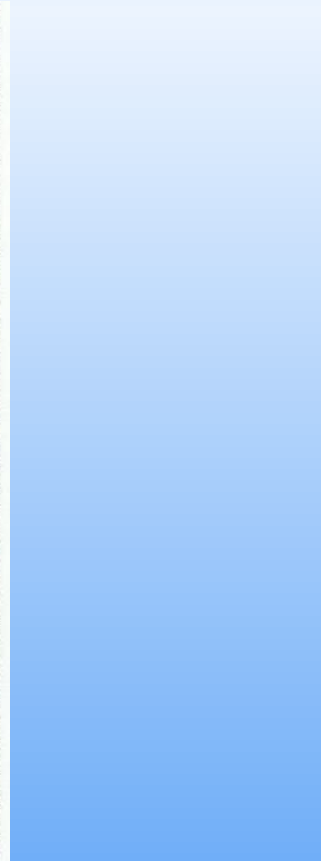

# Important to Know About Underride

- **Geometric Mismatch between bumpers – occurring at the rear, side & front of trucks**
- **Passenger Compartment Intrusion (PCI)**
- **Underride bypasses cars' crashworthy features**
- **It's not the crash that kills, it's the underride!**



Underride happens with Single Unit Trucks as well as tractor trailers.

The front of a  
truck can go  
over a car



Ford  
Windstar

Hyundai  
Sonata

Kia  
Spectra



**Victims of preventable underride include not only occupants of passenger vehicles but also Vulnerable Road Users, including pedestrians, bicyclists, and motorcyclists.**



## **Underride Is A Major Factor In Vulnerable Road User Collisions With Trucks**

**One example is Sylvia Bingham:**

**“As a cyclist, she was hit by a straight truck and went underneath that straight truck.”**

**“It’s not the initial impact. It’s when they go underneath the truck, and they’re hit by the back wheel.”**





# The Million \$ Question:

**Is it technologically,  
practically, and  
economically feasible  
to STOP underrides?**



The difference a well-designed underride guard can make



***SAFETY SKIRT™***

*www.TrailerGuards.com*





## Crash Test of Rear Impact Guard Retrofit

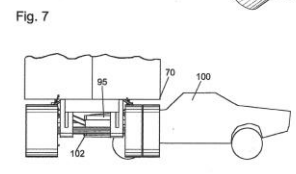
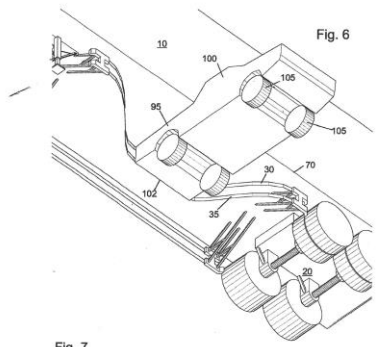

P. BAWKSWORTH.  
SAFETY DEVICE FOR MOTOR VEHICLES.  
APPLICATION FILED NOV. 22, 1915.  
Patented Feb. 2, 1916.  
1,197,941.

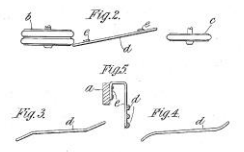
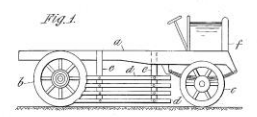

Witness  
W. E. McKeade  
C. W. Kline

Inventor  
Percy Bawksworth  
By  
John L. Davis  
attorney





**Side Guards Save Lives**



**Safety Skirt Crash Test in DC**



**Aerial View of Safety Skirt Crash Test**



**How Side Guards Protect Pedestrians & Cyclists**

**We've waited  
53 years.**

**“It is anticipated that the proposed Standard will be amended, after technical studies have been completed, to extend the requirement for underride protection to the sides of large vehicles.”**

Federal Register, Vol. 34, No. 53 —  
Wednesday, **March 19, 1969**

**Fix the underride problem  
NOW!**

# **On a mission to make truck crashes more survivable**

## **Multi-prong Strategy**

- **Petitioning USDOT**
- **Raising national underride awareness**
- **Communication with the industry**
- **Supporting research efforts (including NC engineer/crash reconstructionist Aaron Kiefer)**
- **Introduction of underride legislation – new & retrofit**





"Blood has been shed, heads literally have rolled and countless thousands of Americans have been injured because these agencies did not act. Further inaction would be inexcusable."

*William Haddon, M.D.*

## Timeline of Underride Safety

**The 2021 Bipartisan Infrastructure Law includes an Underride Section for NHTSA to issue an improved rear guard rule for new trucks and additional research on side underride. Now it's up to Secretary Buttigieg to determine, by November 15, 2022, whether a side guard regulation is "warranted."**

**Unfortunately, there is no guarantee what he will decide or how quickly the USDOT will move.** *(Congressman Price to Sec. Chao)*

# Proposal for Action by the NC ECHS

- **Resolution**
- **Letter of Support**

**Send a strong message to Secretary Pete Buttigieg. Let him know that you want him to require side guards on large trucks.**

# Next Steps

Encourage NC state lawmakers to introduce a side guard law. (Current action in other states)

Support the petition to the NC DOT for an amendment to the rear underride guard rule (p.6) requiring commercial motor vehicles to be equipped with a rear underride guard which meets or exceeds the Insurance Institute for Highway Safety TOUGHGuard standard in order to save lives on North Carolina roads.







**SUBCOMMITTEE ON TRANSPORTATION, HOUSING AND URBAN  
DEVELOPMENT AND RELATED AGENCIES**

**The U.S. House of Representatives  
Committee on Appropriations**

**Department of Transportation  
Budget Request**

**Thursday, February 27, 2020  
10:00 A.M.**

**House of Representatives  
www.house.gov**

**Congressman Price questions Secretary Chao on Override Timeline**